

Which Attribute of Ceiling Color Influences Perceived Room Height?

Christoph von Castell , Heiko Hecht, and Daniel Oberfeld ,
Johannes Gutenberg-Universität Mainz, Germany

Objective: We investigate effects of the hue, saturation, and luminance of ceiling color on the perceived height of interior spaces.

Background: Previous studies have reported that the perceived height of an interior space is influenced by the luminance of the ceiling, but not by the luminance contrast between ceiling and walls: brighter ceilings appeared higher than darker ceilings, irrespective of wall and floor luminance. However, these studies used solely achromatic colors. We report an experiment in which we extend these findings to effects of chromatic ceiling colors.

Methods: We presented stereoscopic room simulations on a head-mounted display (Oculus Rift DK2) and varied hue (red, green, blue), saturation (low, high), and luminance (bright, dark) of the ceiling independently of each other.

Results: We found the previously reported ceiling luminance effect to apply also to chromatic colors: subjects judged brighter ceilings to be higher than darker ceilings. The remaining color dimensions merely had a very small (hue) or virtually no effect (saturation) on perceived height.

Conclusion: In order to maximize the perceived height of an interior space, we suggest painting the ceiling in the brightest possible color. The hue and saturation of the paint are only of minor importance.

Application: The present study improves the empirical basis for interior design guidelines regarding effects of surface color on the perceived layout of interior spaces.

Keywords: ceiling color; luminance; brightness; hue; saturation; perceived height; interior space; architecture

INTRODUCTION

Textbooks on interior design and home improvement provide detailed guidelines for the choice of the appropriate ceiling paint (i.e., the surface color of the ceiling). Besides aesthetic considerations, it is often highlighted that ceiling color has the power to alter the perceived layout of interior spaces (e.g., Gießler, 1990; Meerwein, Rodeck, & Mahnke, 2007; Neufert & Kister, 2009). These recommendations implicitly refer to three perceptual and colorimetric properties of color (cf. Boyce, 2014; Fairchild, 2005; Wyszecki & Stiles, 2000), which are *hue* (e.g., red, green, blue), *brightness* (perceived luminance / intensity of light [see also Gilchrist, 2007]; e.g., bright vs. dim), and *saturation* (difference to an achromatic stimulus of the same brightness, i.e., a neutral gray).

To name just a few such recommendations, Meerwein et al. (2007, pp. 67–69) suggested with respect to saturation that pure colors appear “heavier” and more “oppressive” (in the sense that a ceiling painted in such a color appears lower) than pale colors. With respect to hue, they proposed that reddish and greenish colors appear more “confining” as compared with blueish ceiling colors. For brightness, darker shades of a given color are supposed to be more “confining” and “oppressive” than brighter shades of the same color. In sum, in order to increase the perceived height of a given interior space, e.g., a low basement room, these recommendations would speak for the choice of a bright blueish or achromatic (e.g., white) ceiling color. Moreover, Meerwein et al. (2007) and Gießler (1990, p. 99) suggest that the combination of a bright ceiling color with a slightly darker wall color should maximize the heightening effect of bright ceiling colors, thus implicating contrast.

Probably in the course of the growing do-it-yourself movement, such design recommendations

Address correspondence to Christoph von Castell, Johannes Gutenberg-Universität Mainz, Wallstraße 3, Mainz, 55122, Germany; e-mail: castell@uni-mainz.de.

HUMAN FACTORS

Vol. 60, No. 8, December 2018, pp. 1228–1240

DOI: 10.1177/0018720818789524

Copyright © 2018, Human Factors and Ergonomics Society.

increasingly attract the interest of the broader public, as witnessed by many websites that provide design tips on using ceiling paint to increase the perceived height of interior spaces (e.g., Frake, 2014; van Graan, 2017; a search-engine request with the keywords “ceiling color” yielded 571,000 hits). Given these detailed recommendations, one should think that there is a sound empirical basis to back them up. However, this is not the case. Whereas the effect of surface brightness on the perceived layout of interior spaces has been investigated, we are not aware of studies measuring effects of hue or saturation on the perceived height, width, or depth of rooms.

Compatible with some of the design guidelines mentioned above, several studies from our lab showed that when *achromatic* surface colors are used (i.e., white or gray), interior spaces with brighter ceilings appear higher as compared with darker ceilings (Oberfeld & Hecht, 2011; Oberfeld, Hecht, & Gamer, 2010; von Castell, Hecht, & Oberfeld, 2017). For example, Oberfeld et al. (2010) presented full-scale three-dimensional (3D) room simulations with light-gray, medium-gray, and dark-gray ceilings and found that the light-gray ceilings were perceived as higher than the medium- or dark-gray ceilings. They also reported a small additive effect of wall luminance, in the sense that a room with a bright ceiling and bright walls looked slightly higher than the same room with a bright ceiling and darker walls, speaking against the design guideline that called for contrast (bright ceiling and darker walls to maximize perceived height; Gießler, 1990; Meerwein et al., 2007). The conclusion we can draw from previous studies presenting achromatic surface colors is that brighter ceilings appear indeed higher than darker ceilings.

However, we are not aware of any empirical study testing effects of *chromatic* surface color (be it of the ceiling, the walls, or the floor) on the perceived layout (i.e., perceived width, depth, or height) of interior spaces. In contrast, several studies have considered effects of color on the perceived distance of relatively small objects that covered only a few degrees of viewing angle in the observer’s visual field. Here, not the luminance of the object per se, but the luminance contrast

between adjacent regions modulates depth perception (e.g., Dresch-Langley & Reeves, 2014; Dresch, Durand, & Grossberg, 2002; Egusa, 1983; Farnè, 1977; Ichihara, Kitagawa, & Akutsu, 2007; Mount, Case, Sanderson, & Brenner, 1956; O’Shea, Blackburn, & Ono, 1994; Rempel, Heidrich, & Mantiuk, 2011; Rohaly & Wilson, 1999). For example, when presenting a horizontal arrangement of vertical bars that differ in luminance on a medium-gray background, the black and white bars are perceived as standing out more strongly against the background and, thus, look closer to the observer than gray bars with only a small luminance contrast to the background (cf. Farnè, 1977). Dresch-Langley and Reeves (2014) asked subjects to decide whether an array of small colored squares (red, green, blue, or yellow) was in the foreground or background of a uniformly gray patch. They reported that the proportion of “foreground” responses increased with the luminance contrast between the array and the patch. Moreover, the arrays were more likely perceived to be in the foreground when the color of the squares was highly saturated. In addition, the hue of the array did not significantly affect the foreground-background decisions. Similarly, Mount et al. (1956) found that independently of the hue, chromatic targets were perceived as being closer than achromatic targets. They suggested a saturation effect rather than a hue effect. In contrast, Egusa (1983) reported that subjects who directly compared two adjacent hemifields of different hues perceived red to be nearest, followed by green and blue.

Can we then anticipate effects of saturation and hue on the perceived height of interior spaces on the basis of these results? Comparing the effects of luminance on the perceived height of interior spaces with those on the perceived distance to small objects, it becomes evident that it would be premature to do so. In interior spaces, a brighter ceiling is perceived farther away from the observer than a darker ceiling, irrespective of the luminance contrast between ceiling and walls (Oberfeld & Hecht, 2011). In contrast, the perceived distance to small objects decreases as the luminance contrast between object and background increases, irrespective of object luminance per se. Thus, it seems that the perceived distance to small objects and the perceived

distance to large surfaces, as they occur in interior spaces, do not follow the same rules.

Against this backdrop, the present study was aimed at answering two questions: (1) Can the luminance effect obtained for achromatic ceiling colors be transferred to chromatic ceiling colors? If so, we would expect that brighter ceilings look higher than darker ceilings of the same hue and saturation. (2) Do hue and saturation of a ceiling color also influence the perceived height of interior spaces? For saturation, following the architects' guidelines cited above, the perceived height of a given interior space should be greater for a low-saturated (pale) ceiling color as compared with a high-saturated (pure) ceiling color of the same luminance and hue. With regard to hue, again following the architects' guidelines, when luminance and saturation are kept constant, we should expect that red or green ceilings appear lower than blue ceilings. To answer these questions, we presented full-scale stereoscopic room simulations and varied luminance, hue, and saturation of the ceiling color—as well as ceiling height—independently of each other and asked participants to estimate the height of these interior spaces.

METHOD

Participants

Twenty-two observers (10 women and 12 men), ages 19 to 34 ($M = 23.95$ years, $SD = 3.57$ years), participated voluntarily in the experiment. Two additional participants failed to complete the experiment and were therefore excluded from all analyses. According to the Declaration of Helsinki, all participants gave their written informed consent. They were uninformed about the objective of the experiment. Before the experiment, potential risks were explained to the participants. After the experiment, they were informed about the intention of the experiment.

All participants were familiar with the metric system and had normal or corrected-to-normal visual acuity (i.e., contact lens wearers; eyeglass wearers were excluded from participation because of the limited space available inside the head-mounted display), normal stereoscopic acuity, and normal color vision. The visual acuity of all participants was 1.00 (Snellen fraction

6/6) or better, as confirmed by the Freiburg Visual Acuity Test (FrACT; Bach, 1996). Stereoscopic acuity was tested using a digital version of the Titmus test (Bennett & Rabbetts, 1998) with stereoscopic disparities of 800, 400, 200, 140, 100, 80, 60, 50, and 40 seconds of arc. In the Titmus test, at least six of the nine trials had to be answered correctly in order to qualify for participation. Color vision was tested using the Ishihara (2013) color vision deficiency test (test plates 1, 4, 7, 13, 15, and 20; presented under a D65 standard illuminant).

Stimuli and Apparatus

On each trial, we presented one rectangular room stereoscopically on a head-mounted display (HMD). The ceiling color of the rooms was varied between trials. We presented 12 different chromatic ceiling colors (see Figure 1): two luminance levels (Y , bright, dark) factorially combined with three hues (h ; red, green, and blue) and two saturation levels (S ; low, high). We additionally presented two achromatic, gray ceiling colors, which were luminance-matched to the two luminance levels of the chromatic ceiling colors (bright, dark; see Figure 1). The colorimetric values of the light-gray walls and the dark-gray floor remained constant. Table 1 displays the colorimetric values of the presented surface colors, as measured by means of a spectroradiometer (Specbos 1201).

The ceiling height of the simulated rooms was varied (2.90, 3.00, and 3.10 m; see Figure 2, side view). The width and depth of the simulated rooms was set constant at 4.50 m and 5.80 m, respectively (see Figure 2, top view). All surfaces were overlaid with a fine-grained texture in order to make the surfaces look more realistic. The rooms were illuminated by means of a D65 invisible light source positioned in the center of the room.

The observer's virtual position remained constant at 20 cm in front of the simulated room's invisible front wall, horizontally centered between the left and the right side wall such that the distance between the observer's eyes and the rear wall was 5.60 m (see Figure 2, top view). The virtual viewing direction was horizontally and vertically perpendicular to the room's rear wall. Subjects were instructed that their virtual position was like sitting on a chair and leaning

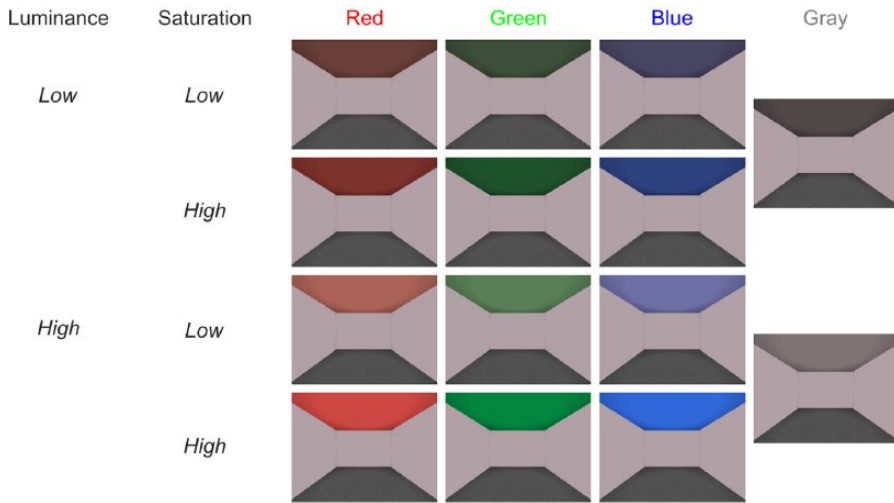

Figure 1. Two-dimensional screenshots of the 14 presented ceiling colors. Columns 1 to 3 show the 12 chromatic ceilings, each 4 presented in red (column 1), green (column 2), and blue (column 3) hue, low (rows 1 and 2) and high (rows 3 and 4) luminance, and low (rows 1 and 3) and high (rows 2 and 4) saturation. Column 4 shows the 2 luminance-matched achromatic ceilings. Note that the colors in the figure are not calibrated and therefore do not provide an exact representation of the colors presented in the experiment on a calibrated display. The ceiling height was 3.00 m in all screenshots.

with their back against the horizontal center of the simulated room’s front wall.

The geometric field of view (gFOV; enclosed visual angle of the projection) was approximately 100° horizontally × 100° vertically. The virtual field of view (vFOV; visible area of the simulated room) corresponded to the gFOV (see Figure 2, top and side view). Subjects’ head position was fixed by means of a chin rest. The virtual eye height was set constant at 1.30 m (see Figure 2, side view) and corresponded to physical eye height.

The stimuli were generated using Vizard 5 (WorldViz, 2016) on a Core i5 computer with an NVIDIA QuadroFX1800 graphics board and presented on an HMD (Oculus Rift DK2™ [second developer kit]). It had a display resolution of 960 × 1,080 pixels per eye (horizontal × vertical), a color resolution of 8 bits per channel, and a refresh rate of 75 Hz. We used this display because of the large gFOV and the excellent color rendering properties of its OLED (organic light-emitting diode) display. We did not use head tracking, so that the display setup corresponded to stereoscopic presentation on an HMD, but not to a “virtual reality” display. The

observer could not explore the simulated interior space with head movements. The individual interpupillary distance of each subject was measured with the aid of a pupil distance meter (bon PD-2) before the experiment and taken into account when computing the binocular disparity of the images presented to the left and right eye.

Design and Procedure

We presented 14 ceiling colors combined with 3 ceiling heights in a fully crossed within-subjects design, resulting in 42 experimental conditions. The experiment consisted of two sessions of five blocks each. In each block, the 42 experimental conditions were presented in random order. Thus, in total, each condition was presented 10 times. In session 1, subjects additionally completed 14 training trials (drawn at random from the 42 trials) before they started with the first test block. The training trials were not taken into account in the data analyses. The time interval between session 1 and 2 was minimally 1 hour and maximally 1 week. In total, the experiment consisted of 434 trials per subject and lasted approximately 130 min (60 to 70 min per session).

TABLE 1: Colorimetric values of the presented surface colors.

Surface	Hue	Luminance	Saturation	X	Y (cd/m ²)	Z	L*	S	h* (deg)
Ceiling	Red	Low	Low	5.83	4.73	3.11	25.94	60.83	33.26
			High	7.43	4.77	1.80	26.06	83.19	33.11
		High	Low	17.63	13.76	8.26	43.89	59.82	33.74
			High	22.93	13.72	4.27	43.82	82.52	33.01
	Green	Low	Low	3.44	4.78	3.15	26.10	59.47	145.64
			High	2.47	4.72	1.77	25.91	83.21	146.68
		High	Low	9.31	13.72	8.20	43.83	59.90	146.10
			High	6.52	13.71	4.16	43.81	82.39	146.17
	Blue	Low	Low	4.73	4.77	10.41	26.08	59.98	278.07
			High	4.87	4.78	18.49	26.10	83.06	276.42
		High	Low	13.61	13.77	32.64	43.91	58.19	276.57
			High	14.20	13.73	61.85	43.84	82.39	276.86
(Gray)	Low	—	4.48	4.70	5.22	25.87	3.34	284.71	
	High	—	13.02	13.78	14.97	43.91	1.19	233.74	
Walls	(Gray)	—	—	28.55	30.06	33.13	61.71	1.98	280.13
Floor	(Gray)	—	—	5.81	6.53	7.40	30.71	14.47	199.39

Note. Columns X, Y, and Z display the CIE XYZ tristimulus values according to the 10° CIE 1964 standard observer (Commission Internationale de l'Éclairage, 2006), columns L* and h* display the lightness and hue values according to the CIE LCh 1976 system (Commission Internationale de l'Éclairage, 2007), column S displays the saturation values calculated from the LCh 1976 chroma (C*) values: $S = C^{*2} / (C^{*2} + L^{*2})^{1/2} \cdot 100\%$ (cf. Lübke, 2013). L*, S, and h* are specified relative to a D65 white point.

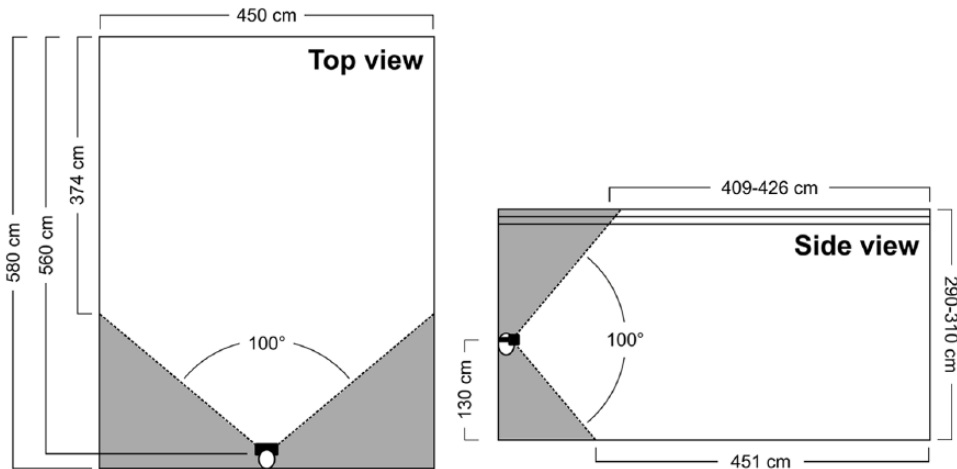

Figure 2. Top view (left-hand side) and side view (right-hand side) of the observer's virtual position relative to the simulated rooms. Within the simulated rooms, the gray-shaded areas were not visible to the observer.

Subjects were tested individually in a dimly lit rectangular office room with approximately 12.50 m² surface area and 3.00 m ceiling height.

Subjects were instructed that the average height of the simulated rooms corresponded to the height of the room where the experiment was

conducted but remained uniformed regarding its actual height. On each trial, the stimulus was presented for 5 seconds. Subsequently, subjects provided a verbal estimate of the ceiling height of the presented room in units of meters and centimeters. No time limit was given for the response. The experimenter entered the estimate using the computer keyboard and then advanced to the next trial.

RESULTS

We analyzed the subjects' mean ceiling height estimates in the 42 experimental conditions, averaged across the 10 repetitions per condition. Individual means were corrected for outliers using the Tukey criterion. Estimates more than 1.5 times the interquartile range lower than the first quartile or higher than the third quartile were classified as outliers and excluded from further analyses. This affected only 123 of the 9,240 estimates (1.33%). We first report the results for the chromatic ceilings and then the results for the achromatic ceilings.

Chromatic Ceilings

Figure 3 shows the mean height estimates for the chromatic ceilings. We analyzed the mean height estimates for the chromatic ceilings by means of a luminance \times hue \times saturation \times ceiling height repeated measures analysis of variance (rmANOVA) using a univariate approach with Huynh & Feldt (1976) correction for the degrees of freedom (correction factor $\hat{\epsilon}$). The α -level was 5% in all analyses. The effect of ceiling luminance on the height estimates was significant, $F(1,21) = 4.597$, $p = .044$, $\eta_p^2 = .180$, Cohen's (1988) $d_z = 0.47$. On average, brighter ceilings were estimated to be 1.40 cm higher ($SD = 2.97$ cm) than darker ceilings (see Figure 3, panel A). The effect of hue was also significant, $F(2,42) = 4.193$, $p = .022$, $\eta_p^2 = .166$, $\hat{\epsilon} = 1.000$. As shown in Figure 3, panel B, on average, the green ceilings were perceived as being slightly lower than the red and blue ceilings. The latter two were virtually identical in perceived height. As a post-hoc analysis, we compared the mean estimates for the red, blue, and green ceilings (averaged across the levels of luminance, saturation, and ceiling height) by

means of paired-samples t -tests (two-tailed). The t -tests showed that the mean estimate for the green ceilings was significantly smaller than the mean estimates for the red ceilings, $t(21) = 2.309$, $p = .031$, $d_z = 0.49$, and the blue ceilings, $t(21) = 2.761$, $p = .012$, $d_z = 0.59$. The difference between the red and the blue ceilings was not significant, $t(21) = 0.005$, $p = .996$, $d_z = 0.00$. In the rmANOVA, the effect of saturation was not significant, $F(1,21) = 0.077$, $p = .785$, $\eta_p^2 = .004$, $d_z = 0.04$. As can be seen in panel C, the mean height estimates were virtually unaffected by the variation of saturation. The effect of ceiling height was significant, $F(2,42) = 88.601$, $p < .001$, $\eta_p^2 = .808$, $\hat{\epsilon} = .583$. Mean height estimates increased with simulated ceiling height, confirming that subjects really judged the rooms' height.

The rmANOVA showed also a significant luminance \times hue \times ceiling height interaction, $F(4,84) = 3.087$, $p = .024$, $\eta_p^2 = .128$, $\hat{\epsilon} = .909$. As depicted in Figure 4, for low-luminance ceilings, we found the strongest effect of hue on perceived height at the tallest ceiling height (3.10 m) (left panel), whereas for high-luminance ceilings, we found the strongest effect of hue at the lowest (290 cm) and the medium ceiling height (300 cm) (right panel). To gain further insight into this interaction, we calculated paired-samples t -tests comparing the mean height estimates for red, green, and blue ceilings on each factorial combination of luminance and ceiling height, averaged across the two levels of saturation. For low-luminance ceilings, green ceilings appeared significantly lower compared with blue ceilings at the tallest ceiling height, $t(21) = 3.116$, $p = .005$, $d_z = 0.66$. For high-luminance ceilings, green ceilings appeared significantly lower compared with red ceilings at the lowest ceiling height, $t(21) = 2.372$, $p = .027$, $d_z = 0.51$, and green ceilings appeared significantly lower compared with red and blue ceilings at the medium ceiling height, $t(21) = 2.651$, $p = .015$, $d_z = 0.57$ and $t(21) = 3.758$, $p = .001$, $d_z = 0.80$, respectively. All other comparisons were not significant (p -values $> .11$). Thus, the effect of hue varied as a function of luminance and ceiling height. However, we do not have a definite explanation for this finding. In the rmANOVA, all other effects were not significant (p -values $> .07$).

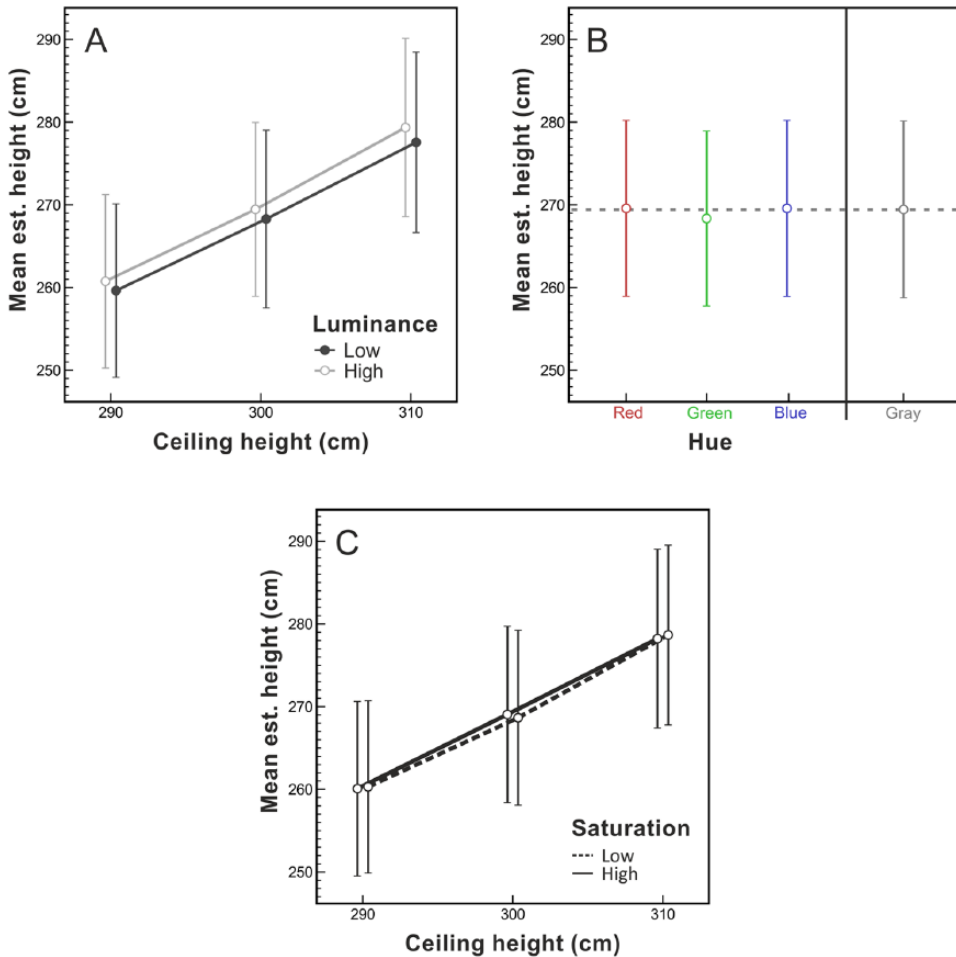

Figure 3. Chromatic ceiling colors. Panel A: Mean height estimates as a function of ceiling luminance and ceiling height. Panel B: Mean height estimates as a function of ceiling hue. For comparison purposes, the rightmost data point and the dashed line indicate the mean estimate obtained for the achromatic ceilings. Panel C: Mean height estimates as a function of ceiling saturation and ceiling height. Error bars show ± 1 standard error of the mean (SEM) of the 22 individual height estimates in each condition. For a tabular display and boxplots of the data, please refer to the supplementary material.

Achromatic Ceilings

Figure 5 shows the mean height estimates for the achromatic ceilings. Descriptively, the results are very similar to the results obtained for the luminance manipulation of the chromatic ceiling colors (see Figure 3, panel A). Again, brighter ceilings appeared higher (mean difference = 1.17 cm, $SD = 4.16$ cm) than darker ceilings. However, a luminance \times ceiling height rmANOVA showed that the effect of luminance did not reach significance, $F(1,21) = 1.744$, $p =$

.201, $\eta_p^2 = .077$, $d_z = 0.28$. The luminance \times ceiling height interaction was also not significant, $F(2,42) = 0.014$, $p = .983$, $\eta_p^2 = .001$, $\tilde{\epsilon} = .952$. The simulated ceiling height had the expected significant effect on the height estimates, $F(2,42) = 67.789$, $p < .001$, $\eta_p^2 = .763$, $\tilde{\epsilon} = .792$.

Comparison of the Chromatic and the Achromatic Condition

To compare the effect of ceiling luminance on perceived ceiling height for chromatic and

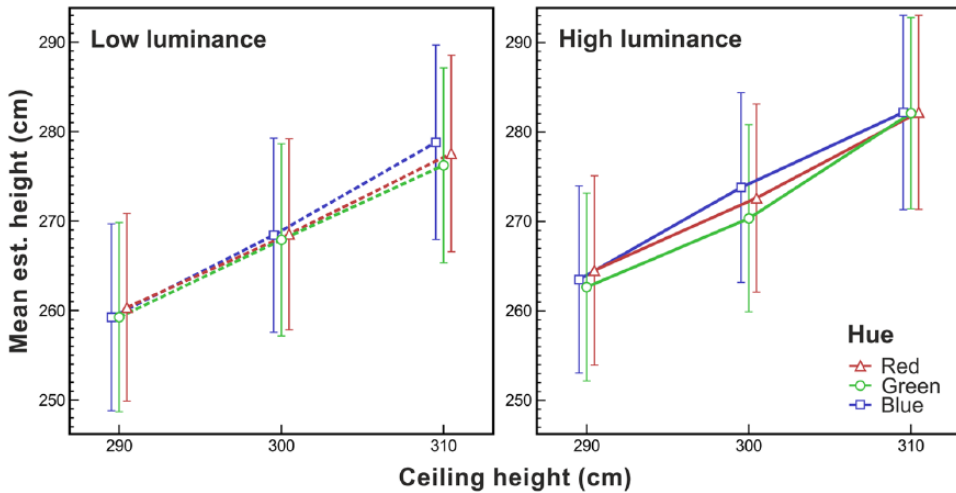

Figure 4. Mean height estimates for the interior spaces with chromatic ceiling colors, as a function of ceiling luminance, ceiling hue, and ceiling height. Error bars show ± 1 SEM of the 22 individual height estimates in each condition. For a tabular display and boxplots of the data, please refer to the supplementary material.

achromatic ceiling colors, we additionally calculated a rmANOVA on judged height with luminance, condition (chromatic, achromatic), and ceiling height as independent variables. For the chromatic ceilings, we averaged the estimates across the levels of hue and saturation. The luminance \times condition interaction was not significant, $F(1,21) = 0.060, p = .809, \eta^2_p = .003$, indicating that the luminance effect is mostly independent of the chromatic attributes of ceiling color. The effect of luminance was not significant, $F(1,21) = 3.278, p = .085, \eta^2_p = .135, d_z = 0.46$, as was to be expected due to the smaller effect of luminance in the achromatic condition compared with the chromatic condition. The effect of condition was also not significant, $F(1,21) = 0.321, p = .577, \eta^2_p = .015, d_z = 0.12$. As depicted in Figure 3, panel B, the mean perceived height of the achromatic ceilings ($M = 269.43$ cm, $SD = 50.15$ cm) was virtually identical to the mean perceived height of the chromatic ceilings ($M = 269.16$ cm, $SD = 49.80$ cm). We additionally calculated paired-samples t -tests comparing the mean estimates for the red, green, and blue ceilings (averaged across the levels of luminance, saturation, and ceiling height) with the mean estimates for the gray ceilings (averaged across the levels of luminance and ceiling height). The comparison of the green and the gray ceilings

just missed significance, $t(21) = 2.054, p = .053, d_z = 0.44$. The comparisons of the red and the gray ceilings, $t(21) = 0.231, p = .820, d_z = 0.05$, and the blue and the gray ceilings, $t(21) = 0.271, p = .789, d_z = 0.06$, were clearly not significant. In the rmANOVA, the effect of ceiling height reached significance, $F(2,42) = 82.024, p < .001, \eta^2_p = .796$. All other effects were not significant (p -values $> .48$).

DISCUSSION

Observers judged the ceiling height of simulated interior spaces with varying chromatic and achromatic ceiling colors. For the case of chromatic ceilings, we found that the perceived height of the simulated rooms increased as the luminance of the ceilings increased, largely independent of the additional variation of saturation, hue, and ceiling height. This finding is compatible with previous results (Oberfeld & Hecht, 2011; Oberfeld et al., 2010; von Castell et al., 2017). There was also a small effect of hue. Controlling for luminance and saturation, rooms with green ceilings appeared slightly but significantly lower than rooms with red, blue, or gray ceilings, with the strongest hue effect observed for medium-high bright ceilings. A potential ecological explanation for this weak effect of hue could be that blue ceilings might

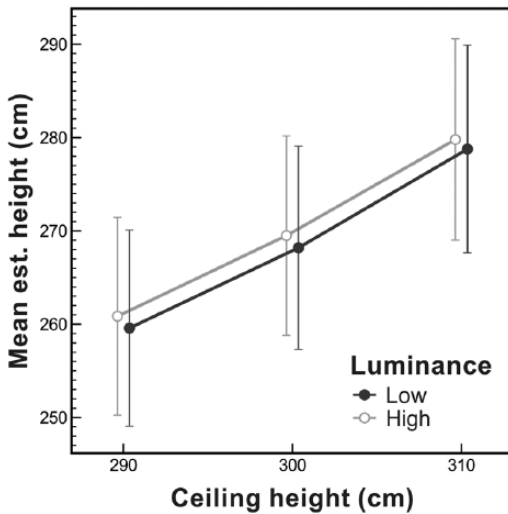

Figure 5. Mean height estimates for the interior spaces with achromatic ceiling colors, as a function of ceiling luminance and ceiling height. Error bars show ± 1 SEM of the 22 individual height estimates in each condition. For a tabular display and boxplots of the data, please refer to the supplementary material.

be associated with the sky whereas green ceilings might evoke the notion of a tree canopy (we thank one of the reviewers for pointing this out). However, further research is required before such speculations can be substantiated. There was no significant effect of saturation: the height estimates for pure ceiling colors and those for pale ceiling colors were almost identical. Additionally, except for the green ceiling, the perceived height of the chromatic (medium and high saturation) ceilings did not differ significantly from the gray (zero saturation) ceilings, providing further evidence that height estimates are independent of the saturation of the ceiling color.

For the case of achromatic ceilings, descriptively, the results were similar to those obtained for the chromatic ceilings. Again, the mean height estimates were greater for brighter ceilings as compared to darker ceilings. However, this effect did not reach significance. In the achromatic condition, the effect size ($d_z = 0.28$) was reduced compared with the chromatic condition ($d_z = 0.47$) and with previous studies (e.g., $d_z = 0.51$ in von Castell et al., 2017). The somewhat

weaker effect of ceiling luminance in the present experiment compared with previous studies (Oberfeld & Hecht, 2011; Oberfeld et al., 2010; von Castell et al., 2017) might be due to the fact that the difference in luminance between the bright and the dark condition ($\Delta Y = 9.0 \text{ cd m}^{-2}$) was smaller than in the previous studies (e.g., $\Delta Y = 16.5 \text{ cd m}^{-2}$ in von Castell et al., 2017). The reason was that within the color gamut of the Oculus Rift DK2 display, we were not able to realize larger luminance differences. When presenting color stimuli on a display, luminance and saturation cannot be varied completely independently of each other across hues. If one takes a red and a blue stimulus, for example, the red stimulus reaches its maximum saturation at a higher luminance level than the blue stimulus. Thus, the presented luminance difference was a trade-off between making the luminance difference as large as possible and keeping the saturation values as constant as possible across hues. Note, however, that despite the somewhat smaller luminance variation the effect of luminance reached significance in the chromatic condition.

How can the weaker and nonsignificant effect of ceiling luminance in the achromatic condition be explained? Because human discrimination threshold curves for luminance differences are very similar for monochromatic and achromatic stimuli (Blackwell, 1972; Wyszecki & Stiles, 2000), it is unlikely that subjects perceived a smaller brightness difference between the two ceiling luminance levels in the achromatic condition as compared with the chromatic condition. Instead, the fact that the effect of luminance was not significant in the achromatic condition could be due to our experimental design. In the chromatic condition, the comparison of the two luminance levels was based on 360 trials per subject, whereas, in the achromatic condition, the comparison was based on merely 60 trials per subject. Thus, in the chromatic condition our design provided more precise estimates of the subjects' individual means and, as a consequence, more sensitivity to detect a potential difference between the two luminance levels, as compared with the achromatic condition.

We conducted the present study in order to answer two questions posed in the introduction of

this article. Our first question addressed the generalizability of the luminance effect obtained for achromatic ceiling colors. On the basis of our results, we propose that the luminance effect does generalize to chromatic ceilings: brighter ceilings appear higher than darker ceilings, independently of whether the ceiling color is chromatic (e.g., red, green, blue) or achromatic (i.e., gray). With regard to our second question of whether hue and saturation of a ceiling likewise influence the perceived height of interior spaces, our data indicate that neither has a sizeable effect on the perceived height of interior spaces, notwithstanding the slightly smaller estimates for green ceilings as compared with all other ceiling colors.

To what extent are our findings applicable to real-world interior spaces? We presented stereoscopic full-scale simulations of interior spaces on an HMD with high resolution and a large geometric field of view. Given the relatively high quality of our visual displays, we assume that our findings concerning ceiling color are applicable to real-world interior spaces. However, a direct experimental comparison of the effects of ceiling color on perceived height in simulated and real interior spaces has yet to be provided. Also, the room simulations were relatively basic. We presented empty interior spaces with blank walls (no furniture, wall decoration, doors or windows) and used rather artificial constant lighting (i.e., an invisible light source positioned in the center of the room). Also, we used static simulations with a fixed virtual observer position, which of course did not provide the full extent of depth cues available when exploring real-world scenes. For studying effects of hue, saturation, and brightness on perceived height, it was important to accurately control the colorimetric coordinates of the presented surface color. The precise colorimetric control we obtained by using the color-calibrated static displays would not have been possible in a dynamic scene rendered in real time. However, there is an obvious need for future research, including rich and high-fidelity dynamic room simulations and an experimental manipulation of, for example, furnishing (Bokharaei & Nasar, 2016; von Castell, Oberfeld, & Hecht, 2014) and lighting conditions (e.g., natural lighting through windows vs. different artificial lighting conditions).

The effect of ceiling luminance on perceived height is in agreement with the interior-design experts' guidelines, which clearly propagate long-lasting effects of surface color on the perceived layout of interior spaces. We therefore assume that the effects we found here for short viewing durations can be applied to the perception of interior space in natural living quarters, although ultimately, this is of course an empirical question.

Is the reported luminance effect specific for the orientation of the surface? Previous studies (Oberfeld & Hecht, 2011; Oberfeld et al., 2010; von Castell et al., 2017) as well as the present study focused on effects of ceiling luminance on the perceived *height* of interior spaces. A recent study from our lab (von Castell, Hecht, & Oberfeld, 2018) indicates that the observed luminance effect can be generalized to the rear and side walls of an interior space and, thus, is independent of surface orientation in space. Using a similar experimental setup as in the present study, we found that room simulations with a light-gray rear wall looked deeper compared with a dark-gray rear wall, and that room simulations with light-gray side walls looked wider compared with dark-gray side walls. Note that this agrees with previous studies regarding effects of surface luminance on the perceived spaciousness of interior spaces (i.e., narrow/cramped vs. spacious/wide; for a detailed discussion, see Imamoglu, 1986; Stamps & Krishnan, 2006; von Castell et al., 2014). In these studies, it has been shown that judged spaciousness increases with increasing wall luminance but remains mostly unaffected by the hue and saturation of the wall color (Franz, 2006; Stamps, 2007).

How do our results compare to the reported architectural guidelines? Be reminded that the architectural guidelines suppose that ceiling colors with high saturation have an "oppressive" effect on the perceived height of interior spaces, suggesting that perceived ceiling height decreases as the saturation of the ceiling color increases. In contrast, our results show that perceived ceiling height is largely unaffected by the saturation of the ceiling color. With regard to hue, following the architectural guidelines, one should have expected both the red and the green

ceilings to lower the rooms' perceived height as compared with the blue and gray ceilings. We found indeed a small albeit significant reduction in perceived ceiling height when the ceiling was green. However, there was no reduction in perceived ceiling height when the ceiling was red. Thus, with regard to hue and saturation, our results for the most part do not support the recommendations made by experts of interior design and decoration.

In the Introduction, we compared previous findings concerning effects of luminance on the perceived distance of large surfaces (e.g., ceiling height) with effects of luminance on the perceived egocentric distance of small objects. How do the effects of hue and saturation on perceived ceiling height observed in the present experiment compare with effects of hue and saturation on the perceived distance to small objects? For the latter, studies reported either no effect of hue, when compared with an achromatic stimulus (Dresp-Langley & Reeves, 2014; Mount et al., 1956), or red appeared closest, when directly compared with another chromatic stimulus (Egusa, 1983). Thus, for the perceived distance to small objects, effects of hue appear to be context-dependent. In either case, these results are not comparable with our finding that green ceilings appear slightly lower and, thus, closer to the observer than red, blue, or gray ceilings. With regard to saturation, previous studies reported that the perceived distance to small objects decreases as their saturation increases. In contrast, we found that the perceived ceiling height was virtually unaffected by the saturation of the paint. In the Introduction, we concluded that effects of luminance on the perceived distance to small objects on the one hand, and on the perceived distance to large surfaces, on the other hand, do not follow the same rules. In sum, the results of the present study indicate that this conclusion can be extended to effects of hue and saturation. These diverging results might arise from various factors. Three aspects seem to be of particular importance: First, our stimuli covered a much larger visual angle than the small objects used in the previous studies. Second, in the present study, observers judged the position of a large surface placed above them, whereas in the case of small objects, observers judged the

egocentric distance of small stimuli positioned in front of them. The third aspect refers to the available contextual information. Our observers were positioned inside a simulated arrangement of surfaces. In contrast, the small objects were presented before a uniform background without further contextual information and were clearly perceived from the outside.

For the interior designer, the following picture emerges. We have previously demonstrated that ceiling and wall brightness affect the perceived height of interior spaces. The remaining perceptual properties of the ceiling color have merely a small effect (hue) or virtually no effect (saturation) on perceived ceiling height. Thus, when the design goal is to maximize the perceived height of an interior space, e.g., of a low basement room, we suggest choosing the brightest possible ceiling color. If, on the contrary, the design goal is to minimize the perceived height of a given room, as may be the case in old buildings with particularly high ceilings, our data plead for choosing a dark ceiling paint. Apart from that, the good news for the designer is that the choice of hue and saturation can be made (almost) entirely on aesthetic grounds, because their effect on the perceived height of an interior space is absent or small. Following these considerations, hue and saturation can be applied in order to obtain a further design goal, such as an intended emotional effect of the paint (e.g., Acking & Küller, 1972; Franz, 2006; Odabasioglu & Olguntürk, 2015; Wilms & Oberfeld, 2017; Yildirim, Hidayetoglu, & Capanoglu, 2011; but see von Castell, Stelzmann, Oberfeld, Welsch, & Hecht, 2018). Note that this does not rule out potential interactions of surface color with other factors that likely do influence the perceived layout of interior spaces, such as furniture and decor.

ACKNOWLEDGMENTS

We are grateful to Agnes Münch for the programming of the experiment. We further thank Robin Welsch and Judith Sturm for collecting the data.

This study was funded by the Deutsche Forschungsgemeinschaft (German Research Foundation): "Innenraumwahrnehmung," HE 2122/10-2 (Heiko Hecht) and OB 346/5-2 (Daniel Oberfeld).

KEY POINTS

- Bright ceiling colors increase the perceived height of interior spaces, independently of hue and saturation.
- Small effect of hue: rooms with green ceilings appear somewhat lower than rooms with red, blue, and achromatic ceilings.
- Judgments of perceived height are largely unaffected by the saturation of the ceiling color.
- Findings of the present study challenge interior design recommendations proposing strong effects of the hue and saturation of the ceiling color on the perceived height of interior spaces.

ORCID ID

Christoph von Castell  <https://orcid.org/0000-0002-0677-1055>

Daniel Oberfeld  <https://orcid.org/0000-0002-6710-3309>

SUPPLEMENTARY MATERIAL

The online supplementary material is available with the manuscript on the *HF* website.

REFERENCES

- Acking, C. A., & Küller, H. (1972). The perception of an interior as a function of its colour. *Ergonomics*, 15(6), 645–654.
- Bach, M. (1996). The Freiburg visual acuity test—automatic measurement of visual acuity. *Optometry and Vision Science*, 73(1), 49–53. doi: 10.1097/00006324-199601000-00008
- Bennett, A. G., & Rabbetts, R. B. (1998). *Clinical visual optics* (3rd ed.). Oxford: Butterworth-Heinemann.
- Blackwell, H. R. (1972). Luminance difference thresholds. In D. Jameson & L. M. Hurvich (Eds.), *Visual psychophysics* (Vol. 7 / 4, pp. 78–101). Berlin: Springer.
- Bokharaei, S., & Nasar, J. L. (2016). Perceived spaciousness and preference in sequential experience. *Human Factors*, 58(7), 1069–1081. doi: 10.1177/00187208166650068
- Boyce, R. B. (2014). *Human factors in lighting* (3rd ed.). Boca Raton, FL: CRC Press.
- Cohen, J. (1988). *Statistical power analysis for the behavioral sciences* (2nd ed.). Hillsdale, NJ: Erlbaum.
- Commission Internationale de l'Éclairage. (2006). Colorimetry - Part 1: CIE Standard Colorimetric Observers (Vol. CIE S 014-1/E:2006 / ISO 11664-1:2008(E)).
- Commission Internationale de l'Éclairage. (2007). Colorimetry - Part 4: CIE 1976 L*a*b* Colour Spaces (Vol. CIE S 014-4/E:2007 (ISO 11664-4:2008)).
- Dresp-Langley, B., & Reeves, A. (2014). Effects of saturation and contrast polarity on the figure-ground organization of color on gray. *Frontiers in Psychology*, 5, 1136. doi: 10.3389/fpsyg.2014.01136
- Dresp, B., Durand, S., & Grossberg, S. (2002). Depth perception from pairs of overlapping cues in pictorial displays. *Spatial Vision*, 15(3), 255–276.
- Egusa, H. (1983). Effects of brightness, hue, and saturation on perceived depth between adjacent regions in the visual field. *Perception*, 12(2), 167–175.
- Fairchild, M. D. (2005). *Color appearance models* (2nd ed.). Chichester, UK: Wiley.
- Farné, M. (1977). Brightness as an indicator to distance: Relative brightness per se or contrast with the background? *Perception*, 6(3), 287–293.
- Frake, D. (2014). Tackling the fifth wall: How to choose ceiling paint color. Retrieved from <http://www.housepaintingtutorials.com/painting-ceilings.html>
- Franz, G. (2006). Space, color, and perceived qualities of indoor environments. In M. K. Tolba, A. Abdel-Hadi & S. Soliman (Eds.), *Environment, health and sustainable development. Proceedings of the 19th International Association for People-Environment Studies Conference (IAPS)*. Seattle, WA, USA Hogrefe & Huber.
- Gießler, J. F. (1990). *Entwurf und Gestaltung für den Innenausbau: Grundlagen und Arbeitsmittel*. [Interior design and planning: Fundamentals and methods]. Stuttgart: Deutsche Verlags-Anstalt.
- Gilchrist, A. L. (2007). Lightness and brightness. *Current Biology*, 17(8), R267–R269.
- Huynh, H., & Feldt, L. S. (1976). Estimation of the Box correction for degrees of freedom from sample data in randomized block and split-plot designs. *Journal of Educational Statistics*, 1(1), 69–82.
- Ichihara, S., Kitagawa, N., & Akutsu, H. (2007). Contrast and depth perception: Effects of texture contrast and area contrast. *Perception*, 36(5), 686–695.
- Imamoglu, V. (1986). Assessing the spaciousness of interiors. *METU Journal of the Faculty of Architecture*, 7, 127–142.
- Ishihara, S. (2013). *The series of plates designed as a test of colour deficiency. 24 plates edition*. Tokyo: Kanehara Trading Inc.
- Lübbe, E. (2013). *Farbempfindung, Farbbeschreibung und Farbmessung. Eine Formel für die Farbsättigung*. [Color perception, color description, and color measurement: A formula for color saturation]. Wiesbaden: Springer Vieweg.
- Meerwein, G., Rodeck, B., & Mahnke, F. H. (2007). *Farbe - Kommunikation im Raum* [Color-communication in architectural space] (4th ed.). Basel: Birkhäuser.
- Mount, G. E., Case, H. W., Sanderson, J. W., & Brenner, R. (1956). Distance judgment of colored objects. *Journal of General Psychology*, 55(2), 207–214.
- Neufert, E., & Kister, J. (2009). *Bauentwurfslehre* [Architects' data] (39th ed.). Wiesbaden: Vieweg & Teubner.
- Oberfeld, D., & Hecht, H. (2011). Fashion versus perception: The impact of surface lightness on the perceived dimensions of interior space. *Human Factors*, 53(3), 284–298. doi: 10.1177/0018720811407331
- Oberfeld, D., Hecht, H., & Gamer, M. (2010). Surface lightness influences perceived room height. *The Quarterly Journal of Experimental Psychology*, 63(10), 1999–2011. doi: 10.1080/17470211003646161
- Odabasioglu, S., & Olguntürk, N. (2015). Effects of coloured lighting on the perception of interior spaces. *Perceptual and Motor Skills*, 120(1), 183–201. doi: 10.2466/24.PMS.120v10x4
- O'Shea, R. P., Blackburn, S. G., & Ono, H. (1994). Contrast as a depth cue. *Vision Research*, 34(12), 1595–1604.
- Rempel, A. G., Heidrich, W., & Mantiuk, R. (2011, August). *The role of contrast in the perceived depth of monocular imagery*. Paper presented at the ACM SIGGRAPH Symposium on Applied Perception in Graphics and Visualization, Toulouse, France.

- Rohaly, A. M., & Wilson, H. R. (1999). The effects of contrast on perceived depth and depth discrimination. *Vision Research*, 39(1), 9–18. doi: S0042-6989(98)00034-0 [pii]
- Stamps, A. E. (2007). Evaluating spaciousness in static and dynamic media. *Design Studies*, 28(5), 535–557. doi: 10.1016/j.destud.2007.01.001
- Stamps, A. E., & Krishnan, V. V. (2006). Spaciousness and boundary roughness. *Environment and Behavior*, 38(6), 841–872. doi: 10.1177/0013916506288052
- van Graan, J. (2017). 6 tricks to make low ceilings look higher. Retrieved 1/10/2018, from <https://www.homify.co.uk/ideabooks/3888655/6-tricks-to-make-low-ceilings-look-higher>
- von Castell, C., Hecht, H., & Oberfeld, D. (2017). Measuring perceived ceiling height in a visual comparison task. *The Quarterly Journal of Experimental Psychology*, 70(3), 516–532. doi: 10.1080/17470218.2015.1136658
- von Castell, C., Hecht, H., & Oberfeld, D. (2018). Bright paint makes interior space surfaces appear farther away. Manuscript submitted for publication.
- von Castell, C., Oberfeld, D., & Hecht, H. (2014). The effect of furnishing on perceived spatial dimensions and spaciousness of interior space. *PLOS One*, 9(11). doi: 0.1371/journal.pone.0113267
- von Castell, C., Stelzmann, D., Oberfeld, D., Welsch, R., & Hecht, H. (2018). Cognitive performance and emotion are indifferent to ambient color. *Color Research & Application*, 43(1), 65–74. doi: 10.1002/col.22168
- Wilms, L., & Oberfeld, D. (2017). Color and emotion: Effects of hue, saturation, and brightness. *Psychological Research*. doi: 10.1007/s00426-017-0880-8
- WorldViz. (2016). Vizard 5 [Computer Software] (Version 5). Santa Barbara, CA: WorldViz.
- Wyszecki, G., & Stiles, W. S. (2000). *Color science: Concepts and methods, quantitative data, and formulae* (Wiley classics library ed.). New York: John Wiley & Sons.
- Yildirim, K., Hidayetoglu, M. L., & Capanoglu, A. (2011). Effects of interior colors on mood and preference: Comparisons of two living rooms. *Perceptual and Motor Skills*, 112(2), 509–524. doi: 10.2466/24.27.pms.112.2.509-524

Christoph von Castell is pursuing a doctoral degree in psychology at the Johannes Gutenberg-Universität Mainz, Germany. He received a master's degree in psychology from the Johannes Gutenberg-Universität Mainz in 2013.

Heiko Hecht holds the chair of experimental psychology at the Johannes Gutenberg-Universität Mainz, Germany. He received his PhD in experimental psychology from the University of Virginia in 1992.

Daniel Oberfeld is an associate professor in the Institute of Psychology at Johannes Gutenberg-Universität in Mainz, Germany. He completed his PhD in psychology from Technische Universität Berlin in 2005.

Date received: October 11, 2017

Date accepted: June 25, 2018